

CHARACTERIZATION AND OPTIMIZATION OF ERBIUM- DOPED FIBER AMPLIFIERS USED IN OPTICAL COMMUNICATION SYSTEMS

Ms. Salema M. Ali (1) and Dr. Ibrahim Mansour (2)

(1) Assistant Lecturer in Communication section, University of Omar Al-Mukhtar – Libya, Electrical Department. almanbis@yahoo.com

(2) Associate professor in Communication section, University of Al-Ahliyya Amman – Jordan , Electrical Department. imansour@ammanu.edu.jo

Abstract

This paper deals with the properties of Erbium-doped fiber amplifiers (EDFAs). The EDFA is an optical amplifier that is used in the 1550 nm window of optical fibers. The objective of this work is to analyze and optimize the performance of EDFA systems with single wavelengths input sources. The Performance of optical communication systems is enhanced by the use of EDF. EDFA is an important element in Coarse Wavelength-Division Multiplexing (CWDM) and Dense Wavelength Division Multiplexing (DWDM) networks. The study can achieve gain spectrum by modeling the dynamic characteristics of an EDFA, and presents basic EDFA model operating on single (1550 nm) wavelength operation with their simulation results, then numerical simulations are used to evaluate the amplifier performance as function of manufacturing parameters and operating conditions, using this numerical model a computer program is developed to calculate the amplifiers gain and noise figure under certain conditions.

The focus in this work is to study deeply EDFAs and then to improve the design for best performance (maximizing gain and reducing noise figure).

Key words: Erbium-doped fiber amplifiers (EDFAs), optical amplifier, gain, noise figure, pump laser, wavelength, Single Stage, and Two- Stages Amplifiers.

Introduction

In long distance communications entail the transmission reception of a large amount of information in a short period of time. This paper investigates certain aspects of one of these technologies, optimization Erbium Doped Fiber Amplifiers (EDFA's), and a technique that involves the transmission of signals over a single optical fiber using different parameters, and to analyze the performance of EDFA systems using Single wavelength Input sources. The performance of an optical communication system can be improved by the use of EDFAs as an optical amplifier. [1, 2] , a study is performed to find the best amplifier parameters that advice power level of the pump which will maximize gain and improve the performance of the device. Therefore, this study investigates in details the optimization process of EDFAs in optical communications networks.

Rare Earth Doped Fiber Amplifier

Different rare-earth ions such as erbium, holmium, thulium and ytterbium can be used to realize fiber amplifiers operating at different wavelength covering from visible to infrared region. In the rare earth doped fiber amplifier, erbium's dopant in silica based single mode fiber is used and is called erbium doped fiber amplifier (EDFA). A piece of fiber gain medium is an active medium that is heavily doped with ions of erbium. In this, population inversion is stronger due to large number of erbium ions that fall into level 2 from various upper levels. [2]. The EDFA consists of three basic components: length of erbium doped fiber, pump laser and wavelength selective coupler to combine the signal and pump wavelengths as shown in (Fig. 1). [1]

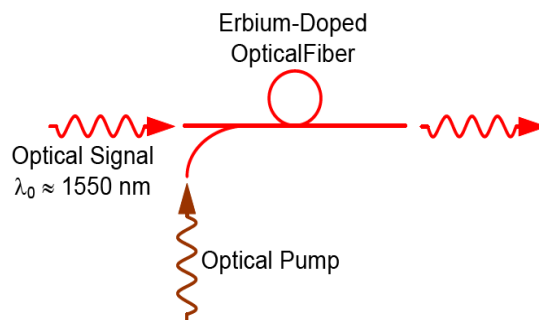

Fig. 1 Erbium doped fiber amplifier (EDFA)

Erbium-Doped Fiber Amplifier

Erbium-Doped Fiber Amplifier (EDFA) is a device that boosts the signal in an optical fiber. Introduced in the late 1980s, the EDFA was the first successful optical amplifier. It was a major factor in the rapid development of fiber-optic networks in the 1990s, because it extended the distance between costly regenerators. [3, 4].

Erbium-Doped Fiber Amplifiers are widely used in fiber-optic communication systems, because they operate in the wavelength region near $1.55 \mu\text{m}$, where optical fibers have their loss minimum. [4].

This amplifiers use trivalent erbium ions (Er^{3+}) as a gain medium by doping the fibre core during the manufacturing process. The Er^{3+} doped fibre is pumped with light from two laser diodes. The pump laser excites ions into a higher energy level from which they decay via stimulated emission of a photon at the signal wavelength back to ground energy level. Amplification is achieved by stimulated emission of photons from dopant ions in the doped fiber. [5].

Amplification Process of EDFA

Erbium doped fiber (EDF) is the main component of an EDFA, which is made by doping erbium ions into the core of alumino-germano-silicate (silica) glass fiber. Erbium is a rare earth element belonging to the group of the Lanthanides, which has many unique intrinsic properties for optical amplification. On the other hand, glass is used as a laser host for its advantages such as optical quality, transparency, low birefringence, high optical damage threshold, thermal shock resistance, weak refractive index nonlinearity, high energy storage and power extraction capacities, variety of possible compositions, size and shape scalability, and low cost of raw

materials. [2]. The EDF is a strong absorbing medium at the wavelength regions of 980 nm and 1480 nm, making them the two main pumping regions. The amplification in the wavelength region of 1550 nm is achieved due to energy characteristic of Erbium ion, which can generate stimulated emission between E_2 to E_1 level when it is pumped by 980 nm or 1480 nm light beam. (Fig. 2) shows the energy level structure of the Erbium ions. [6].

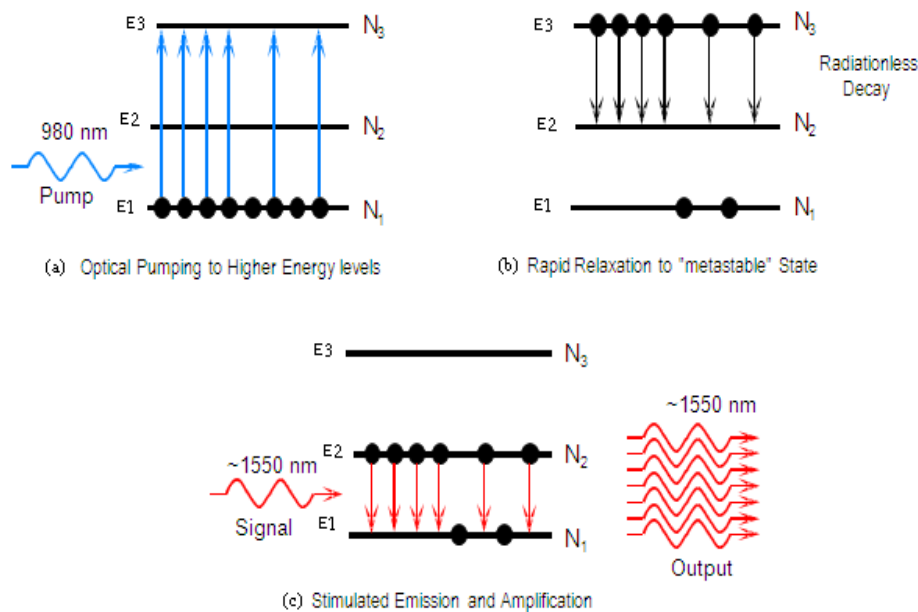

Fig. 2 Optical pumping and emission in Er^{3+} three levels system.

From the above energy level diagram, it is observed that the upper level of the amplifying transition, E_2 , is separated by a large energy gap from the next lowest level, E_1 . The lifetime of this upper level is very long and hence mostly radiative. This long lifetime creates the population inversion between levels E_2 and E_1 for stimulated emission to occur. Incident pump photons at wavelength 980 nm will excite the ions from ground state E_1 to the higher level E_3 . The ions stay at the excited state of E_3 for about 1 μ s and then fast decay to the metastable state, E_2 through a non-radiative transition. The lifetime of the metastable state is approximately 10 ms. Hence, with constant and sufficient pump intensity, population inversion will be achieved between level E_2 and E_1 . From the metastable state E_2 , the ions will decay to the ground state and emit photons either spontaneously or stimulated. The emitted photons have wavelength characteristics around the 1550 nm [6,7].

Due to various line broadening effects, namely the Stark's splitting of the E_2 and E_1 energy levels, the 1550 nm emission band of Er^{3+} ion ranges from 1525 nm to 1565 nm, [2], this is shown diagrammatically by (Fig. 3). Emission can occur in two ways:

1. Spontaneous emission where atoms return to the lower energy level in a random manner. According to quantum mechanics theory, spontaneous emission always involves transition from a higher energy state to a lower energy state. The spontaneous emission produced would become the noise generated by the amplifier and is referred to as ASE.

2. Stimulated emission where a photon (energy carrying atom) having energy equal to the energy difference between E_2 and E_1 interacts with the atoms in E_2 , causing them to return to E_1 along with the creation of more photons. This is also referred to as avalanche multiplication.

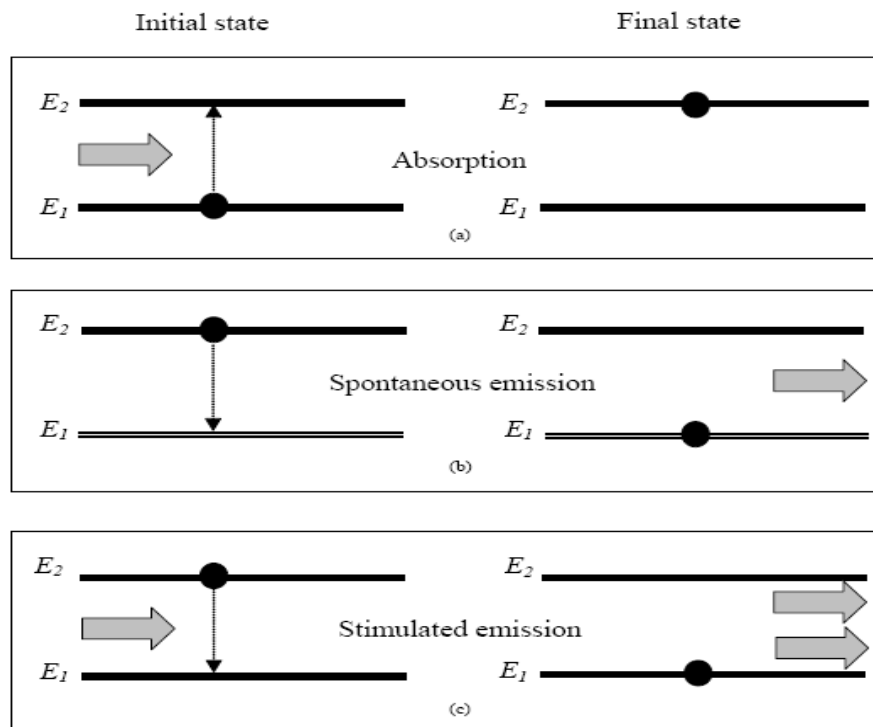

Fig. 3 Schematic representations of absorption and emission between energy level 1 and 2: (a) absorption (b) spontaneous emission and (c) stimulated emission. [6]

Photons produced by stimulated emission are generally of an identical energy to the ones that caused it and hence, the light associated with them is of the same frequency, phase and polarization. Furthermore, when an atom is stimulated to emit light energy by an incident wave, the liberated energy could add to the wave in a constructive manner, providing amplification (coherent emission).

Previous Studies

This part of the work explores the research and the previous studies that are relevant to the proposed topic; there are many previous studies on improving performance of EDFA from several aspects, including:

Gujral (2012) proposed and simulated the EDFA model with single and multi-wavelength sources using pumping source of 980 nm wavelength. The various results were also compared. It is important to understand the desired range of wavelength used in EDFA which provides efficient results. Along with source wavelength if other parameters like pump power, signal power are changed, than optimized values of gain and noise figure are obtained. Thus, they have shown that the proposed model of an EDFA utilizing both single and multi-wavelength sources was successfully simulated using WDM. [6]

Fowzia, et al. (2012) modeled and characterized all possible triple pass EDFA configurations. They determined optimum length and pump power ratio for each configuration and concluded that triple pass EDFA is the best for practical design. [5]

Naji, et al. (2011) proposed a new simulator which is capable of changing design parameters such as length, pump power and they studied their effects on performance parameters. [9]

Adolph, et al. (2006) studied different features features of the amplifier depending upon opto-

geometric parameters and simulation results showed gain, power dependency on internal parameters. [2]

Joon (2004) proposed an all-optical gain clamped Erbium-Doped Fiber Amplifier with improved noise figure. It was based on reflecting amplified spontaneous emission (ASE) into EDFA. They experimentally demonstrated the scheme by using a coarse WDM Coupler at the input fiber. [8]

Characteristics of EDFA

1 -Signal Gain

Signal gain is one of the key characteristics of optical amplifier. The gain, G is defined as the ratio of the output signal power to the input signal power, $G = (P_{s,out}/P_{s,in})$ as shown in (Fig. 4), and typically expressed in dB. [10]

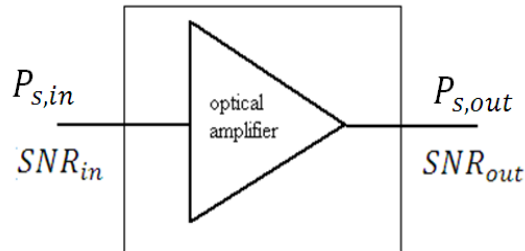

Fig. 4 block diagram of optical amplifier.

The amplifier Gain in dB is defined as:

$$G = 10 \log \left(\frac{P_{s,out}}{P_{s,in}} \right) \text{ unit (dB)} \quad (1)$$

Where $P_{s,out}$ is the output signal power and $P_{s,in}$ is the input signal power. At a specific pump power, an EDFA shall ideally deliver the highest possible signal gain.

2 -Noise Figure

Another important characteristic of EDFA is the noise figure (NF). All laser amplifiers degrade the signal-to-noise ratio (SNR) of the amplified signal because of spontaneous emissions that add to the signal during its amplification. The SNR degradation is quantified through a parameter NF. [8]

Noise figure is a measure of the signal-to-noise power ratio degradation encountered by the signal after passing through the amplifier. The definition of noise figure is the ratio of the signal-to-noise ratio at the input (SNR_{in}) to that at the output (SNR_{out}), [9 ,10], as shown in Figure 4, the amplifier NF is defined as:

$$NF = 10 \log \left(\frac{SNR_{in}}{SNR_{out}} \right) \text{ unit (dB)} \quad (2)$$

The above equation for optical amplifier NF is originated from the electrical domain definition. During the amplification process, the amplifier introduces noise and hence the SNR_{out} is always lower than the SNR_{in} .

The NF of a high gain amplifier is always greater than 2 dB, and NF in an ideal EDFA is 3 dB, while practical amplifiers can have noise figure as large as 6–8 dB. [9]

Software Used

In the designing of the EDF optical amplifier required software is optisystem 7.0, by changing in the operation or design parameters such as input signal power, pump power, pump wavelength, length of active fiber and single stage or two stages EDFAs; different performance parameters (gain and noise figure) can be optimized.

1- Single Stage

Effect of input signal power on gain and noise figure

For this purpose, an EDFA model was built using single wavelength source (1550 nm), and 1480 nm pump wavelength Co-directional (forward Pumping), pump power 80 mW. The proposed model is shown in the (Fig. 5). The parameters Gain and Noise Figure was measured for different signal powers (-40, -30, -20, -10, 0, +10 dBm), when varying lengths (0 - 20 m).

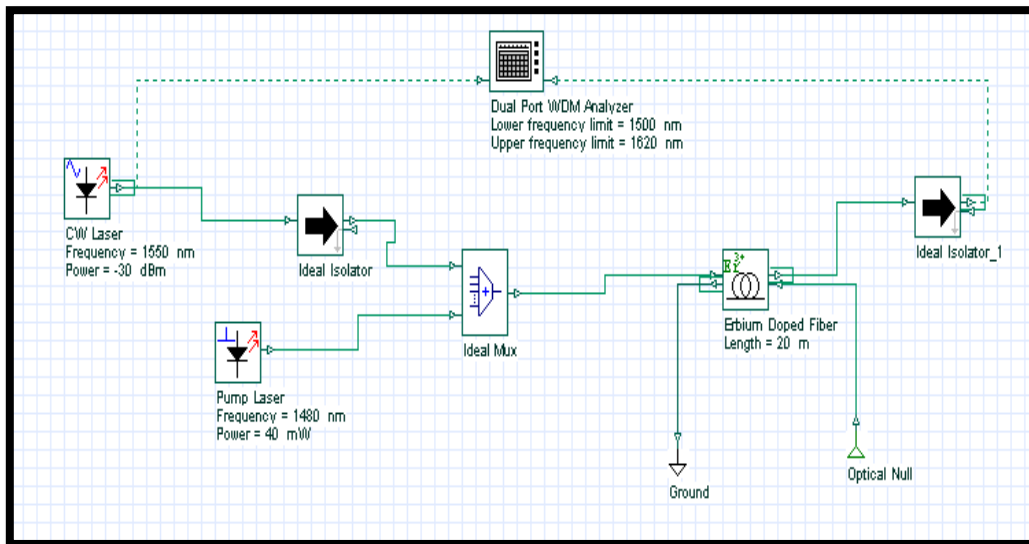

Fig. 5 Single Stage EDF optical amplifier design using scheme of the forward pumping EDFA

Simulation Results shown in (Fig. 6) indicates how Gain is affected by the input signal power. For example; an input signal power of -40 dB, maximum gain is found to be 40.64 dB at fiber length of 10.27 m, while it is 39.77 dB at EDF length 10.10 m when the input signal power is -30 dB.

The simulation results of the effect of input signal power on noise figure are plotted in(Fig.7) shown below.

It is evidenced that the small-signal (low input signal power) has nearly same behavior, which is much better than that of large-signal (high power) – as expected in preamplifier.

Increase in NF with increase in input signal power could be attributed to fast depletion of pump power.

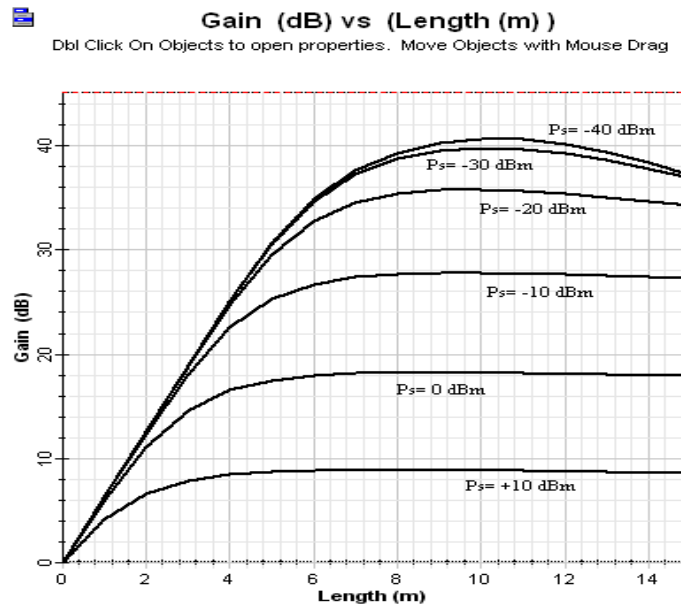

Fig. 6 Variation of gain with different EDF lengths and different signal powers ($\lambda_p = 1480$ nm, and $P_p = 80$ mW)

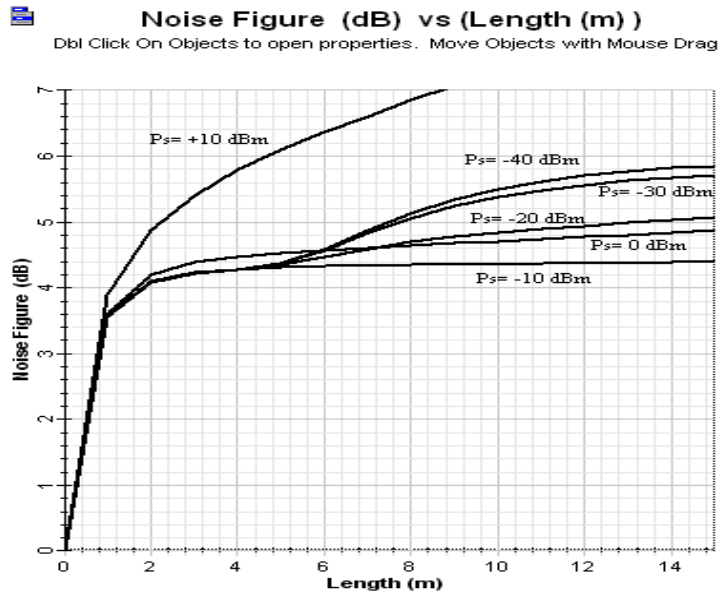

Fig. 7 Variation of noise figure with different EDF lengths and different signal powers ($\lambda_p = 1480$ nm, and $P_p = 80$ mW)

Input signal power has an influence on the gain and on noise Figure. (Table 1) shows the results of comparison of maximum Gain and Noise Figure for different signal power and EDFA optimum length with co-directional Pumping scheme.

Table 1: Results of comparison of maximum Gain and noise figure for different signal power at optimum length with $P_p = 80$ mW.

Signal power (dBm)	Optimum EDF length (m)	Max Gain (dB)	Noise Figure (dB)
-40	10.27	40.64	5.53
-30	10.10	39.77	5.38
-20	9.58	35.73	4.81
-10	9.41	27.75	4.35
0	8.55	18.24	4.65
10	7.34	8.94	6.69

The following points can be deduced from the results listed in (Table 1):

1- As the signal power is increased; the maximum gain is decreased. The large change in Gain is shown in (Fig. 8).and a small change in noise figure approximately (0.2 - 1.5 dB).

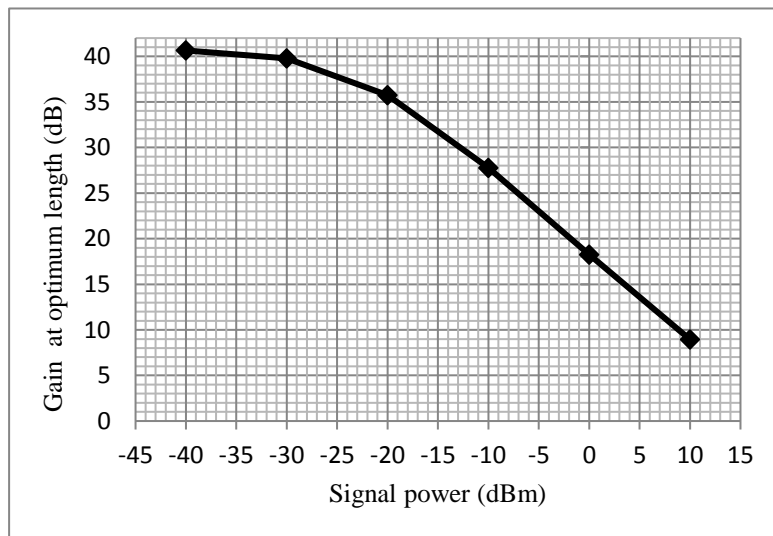

Fig. 8 Variation of max gain at optimum fiber length and different signal powers ($\lambda_p = 1480$ nm, and $P_p = 80$ mW)

2- Signal power -40 dBm with pump power = 80 mW shows highest gain 40.64 dB and with optimum EDFA length is 10.27 m, shown in (Fig. 9). As signal power increases, optimum fiber length decreases.

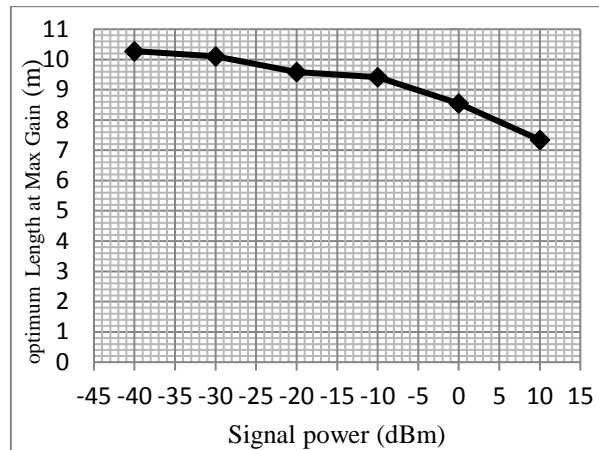

Fig. 9 Variation of optimum EDF lengths at max gain, different signal powers, and ($\lambda_p = 1480$ nm, and $P_p = 80$ mW).

2- Two- Stages Amplifiers

In this section, experiments for two-stages amplifier are studied. Two EDFA are connected in cascade through an isolator and a Band Pass Filter (BPF). (Fig. 10) shows the schematic diagram of the two EDFs. The input is a single wavelength source 1550 nm, of power of -30 dBm. The first stage has a forward pump source of 80 mW at 1480 nm, and fiber length of 10.1 m. The input signal for the second stage is the output signal of the first stage after filtering the residual pump power. Different lengths for the second stage EDF (0 - 20 m) is investigated, with same characteristics of pump used for first stage. The pump power is 80 nm is not completely depleted in the first stage, but when using a BPF the residual pump power is not leaked to the second stage, and the isolator eliminates the backward propagation of ASE generated by the second stage which could deplete the pump of the first stage.

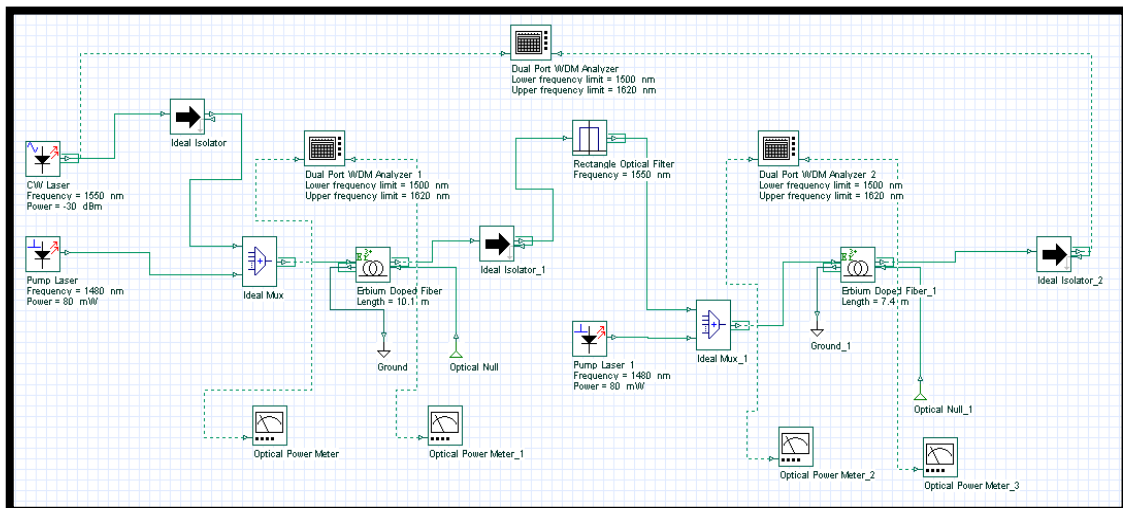

Fig. 10 The schematic Two-stage erbium doped fiber amplifier.

The second stage acts as a power amplifier to boost the signal. The optimum length of EDF is 7.4 m for the second stage. In our design, different fiber lengths and pump power have been

used to optimize system performance at 1550 nm signal, the length of EDF1 and EDF2 are then fixed at 10.1 m and 7.4 m, respectively. (Table 2) shows simulations results for gain and noise figure of the two stages EDFA.

Table 2: Analysis of EDFA gain, noise figure with first-stage, second stage and two-stage EDF optical amplifier.

EDFA parameters	First Stage EDFA	Second Stage EDFA	Two Stages EDFA
Optimum EDF length (m)	10.1	7.4	_____
Maximum Gain (dB)	39.77	9.23	49.00
Noise Figure (dB)	5.386	15.878	5.39

(Fig. 11) shown the maximum gain is 49 dB at optimum length of EDF in the first and second-stage amplifiers, maximum gain for the overall system is the sum of the maximum gain for first stage and second stage.

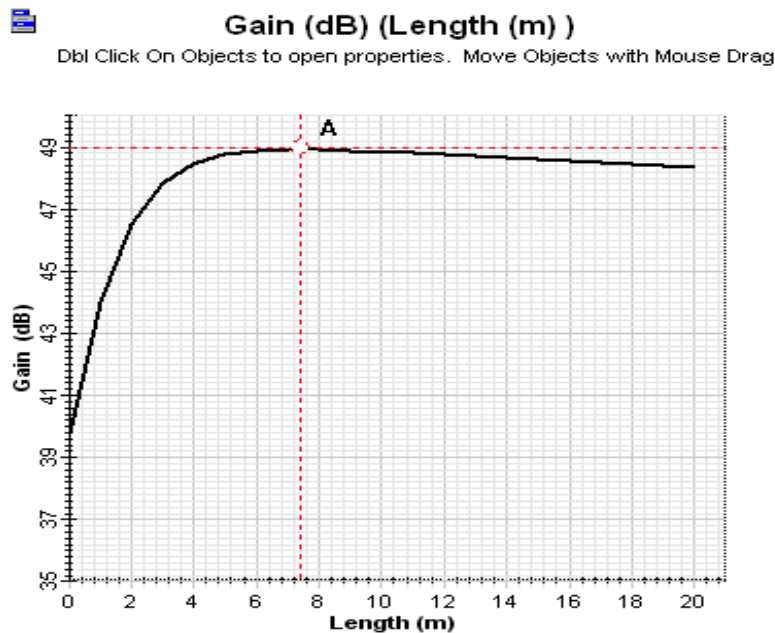

Fig. 11 Variation of gain with optimum lengths of the first stage EDF is 10.1 m, different lengths of the second stage EDF are (0 - 20 m).

The noise figures for first and second-stage amplifiers are ($NF_1 = 5.386$ dB) a ($NF_2 = 15.878$ dB), respectively, noise figure for the overall amplifier is calculated by (Eq. 3), [10]:

$$NF_{total} = NF_1 + \frac{NF_2 - 1}{G_1} = 5.39 \text{ dB} \tag{3}$$

Where G_1 is the gain of first stage.

The key characteristic of a two-stage amplifier is that it reduces a significant portion of ASE, this allows the gain to grow at the expense of ASE and reduces the noise figure.

When comparing and analysing of gain and noise figure using single stage EDFA and two stages EDFA at signal wavelength source (1550 nm), with pump source of 1480 nm wavelength, signal power -30 dBm, and the optimum length of EDF in the first and second-stage amplifiers are 10.1 m and 7.4 m, respectively, as shown in (Table 3).

Table 3: Results of comparison of maximum Gain and noise figure for single stage and two stages EDFA with $P_s = -30$ dBm, $P_p = 80$ mW, and $\lambda_p = 1480$ nm.

EDFA parameters	Single Stage EDFA	Two Stages EDFA
Maximum Gain (dB)	39.77	49.00
Noise Figure (dB)	5.386	5.39

(Table 3) shows that the gain of single stage EDFA is 39.77 dB, and for two stages EDFA the gain is 49 dB, and noise figure (5.386 dB \cong 5.39 dB) almost the same, it is observed that the two-stages EDFA improves the signal gain by 9.23 dB, with no change in NF.

Conclusions

The gain and noise figure characteristics of EDFA with single wavelength source (1550 nm) in an optical system consisting of single stage and two stages amplifiers, using forward pumping source of 1480 nm wavelength. Various results were also compared. It is important to understand the desired range of pump powers used in EDFA which provides efficient results. Along with source wavelength if other parameters like length, signal power are changed , than optimized values of gain and noise figure are obtained.

The Gain spectrum of single wavelength source EDFA of wavelength 1550 nm with input signal power of -30 dB. pumping source 1480 nm, and the gain measured is 39.77 dB,

The high gain in an active fiber causes the spontaneous emission to stay in low levels. The noise figure of EDFA varies linearly with ASE power and inversely with the amplifier gain. Therefore, the noise figure of EDFA can be reduced to a minimum value by increasing gain.

The gain of single stage EDFA is 39.77 dB, and for two stages EDFA gain is 49 dB, and noise figure (5.386 dB \cong 5.39 dB) almost same value, it is observed that the two-stages EDFA improves the signal gain by 9.23 dB, with no change noise figure, thus it is obtained have acquired best result in terms of maximum gain, reducing noise figure and improved the performance of the device.

Thus, results have shown that the proposed model of EDFA utilizing both single wavelength sources was successfully simulated. For each signal power is changed and obtained observed the changes in gain and noise figure, maximum gain and low noise figure can be achieved using the values shown in the results, and using two-stages EDFA without changing every component.

References

- [1] Abedin, K, S. Taunay, T, F. Fishteyn, M. Digiovanni, D, J. and Supradeepa, V, R. (2012). Cladding-pumped erbium-doped multicore fiber Amplifier. Optical Society of America, 20(18).
- [2] Adolph, T. Saadi, O, H. and Boutaleb, A. (2006). Simulation based analysis of erbium doped fiber amplifier (EDFA). Journal of applied science. ISSN 1812-5654: Asian network for scientific information, 6(4), 789-794.
- [3] Desurvire, E. 1994, Erbium-Doped Fiber Amplifiers: principle and applications, John Wiley & Sons, Inc.
- [4] Ee-Leong, L. Shaif, A. and David, J, R. (2012). High-energy, in-band pumped erbium doped fiber amplifiers. University of Southampton, Southampton, SO17 1BJ, UK, 20(17)
- [5] Fowzia, A. Ibrahimy, M, I. Naji, A, W. and Siddiquei, H, R. (2012). Modeling and characterization of all possible triple pass EDFA configurations. International Journal of Physical Sciences, 7(18), 2656-2663.
- [6] Gujral, J. (2012). Analysis of Augmented Gain EDFA Systems using Single and Multi-wavelength Sources. International Journal of Computer Applications, 4(47), 14-21.
- [7] Gyeong, I, K. (2002). Noise Figure of Optical Amplifiers. Journal of the Korean Physical Society, 41(5), 617-628.
- [8] Joon, T. (2004). All-Optical Gain-Clamped Erbium-Doped Fiber Amplifier with Improved Noise Figure and Freedom from Relaxation Oscillation. IEEE Photonics Technology Letters, 1(16), 84-86.
- [9] Naji, W, A. Hamida, B, A. Cheng, X, S. Mahdi, M, A. and Harun, S. (2011). Review of Erbium-doped fiber amplifier. International Journal of Physical Sciences, 6(20), 4674-4689.
- [10] Senior, M, J. and Yousif, M. (2009). Optical Fiber Communications Principles and Practice. Third edition.